

**Allt
mellan
antenn
och jord**

Datum 980623

PRODUKTINFORMATION FRÅN

ELFA



HÄMTFAX
+46 8 735 35 33



FAX ON DEMAND
+46 8 735 35 29



INTERNET
<http://www.elfa.se>

TEKNISK INFORMATION +46 8 735 35 15 ORDERTEL +46 8 735 35 35 ORDERFAX +46 8 730 30 88

— Vi reserverar oss mot fel samt förbehåller oss rätten till ändringar utan föregående meddelande —

**ELFA artikelnr.
70-327-09 BB134 Kapacitansdiod**

Antal sidor: 05

DATA SHEET

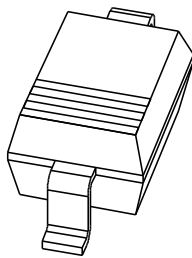

BB134

UHF variable capacitance diode

Product specification
Supersedes data of November 1993
File under Discrete Semiconductors, SC01

1996 May 03

UHF variable capacitance diode

BB134

FEATURES

- Excellent linearity
- Excellent matching to 0.5% DMA
- Very small plastic SMD package
- C28: 1.9 pF; ratio: 10
- Low series resistance.

APPLICATIONS

- Electronic tuning in UHF television tuners
- VCO.

DESCRIPTION

The BB134 is a variable capacitance diode, fabricated in planar technology, and encapsulated in the SOD323 very small plastic SMD package.

The excellent matching performance is achieved by a direct matching assembly procedure. The unmatched type, BB135 has the same specification.

ELECTRICAL CHARACTERISTICS

$T_j = 25\text{ }^\circ\text{C}$; unless otherwise specified.

SYMBOL	PARAMETER	CONDITIONS	MIN.	TYP.	MAX.	UNIT
I_R	reverse current	$V_R = 30\text{ V}$; see Fig.3	–	–	10	nA
		$V_R = 30\text{ V}$; $T_j = 85\text{ }^\circ\text{C}$; see Fig.3	–	–	200	nA
r_s	diode series resistance	$f = 470\text{ MHz}$; note 1	–	–	0.75	Ω
C_d	diode capacitance	$V_R = 0.5\text{ V}$; $f = 1\text{ MHz}$; see Figs 2 and 4	17.5	–	21	pF
		$V_R = 28\text{ V}$; $f = 1\text{ MHz}$; see Figs 2 and 4	1.7	–	2.1	pF
$\frac{C_{d(0.5V)}}{C_{d(28V)}}$	capacitance ratio	$f = 1\text{ MHz}$	8.9	–	12	
$\frac{\Delta C_d}{C_d}$	capacitance matching	$V_R = 0.5\text{ to }28\text{ V}$; in a sequence of 4 diodes (gliding)	–	–	0.5	%
		$V_R = 0.5\text{ to }28\text{ V}$; in a sequence of 15 diodes (gliding)	–	–	2	%

Note

1. V_R is the value at which $C_d = 9\text{ pF}$.

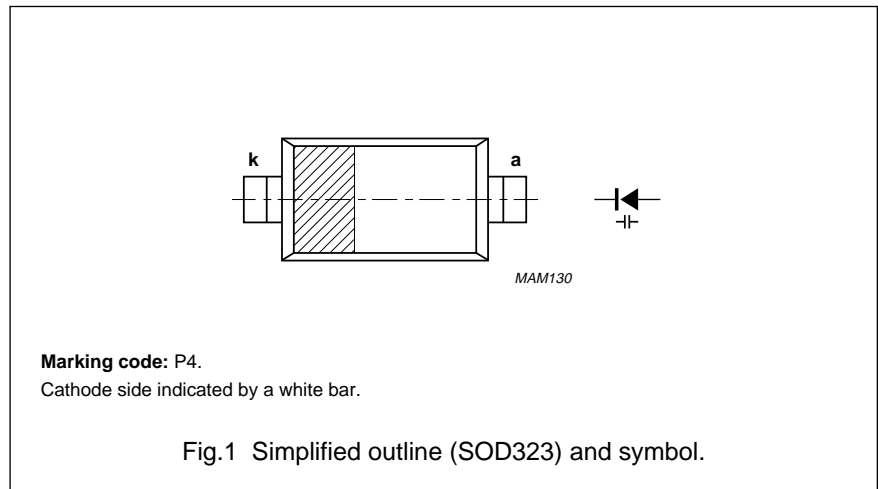

LIMITING VALUES

In accordance with the Absolute Maximum Rating System (IEC 134).

SYMBOL	PARAMETER	MIN.	MAX.	UNIT
V_R	continuous reverse voltage	–	30	V
I_F	continuous forward current	–	20	mA
T_{stg}	storage temperature	–55	+150	$^\circ\text{C}$
T_j	operating junction temperature	–55	+125	$^\circ\text{C}$

UHF variable capacitance diode

BB134

GRAPHICAL DATA

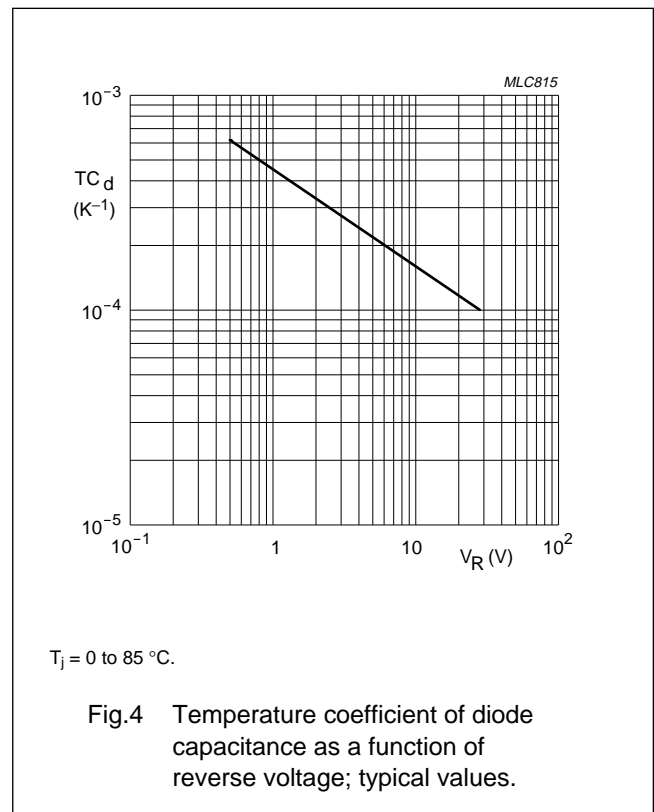
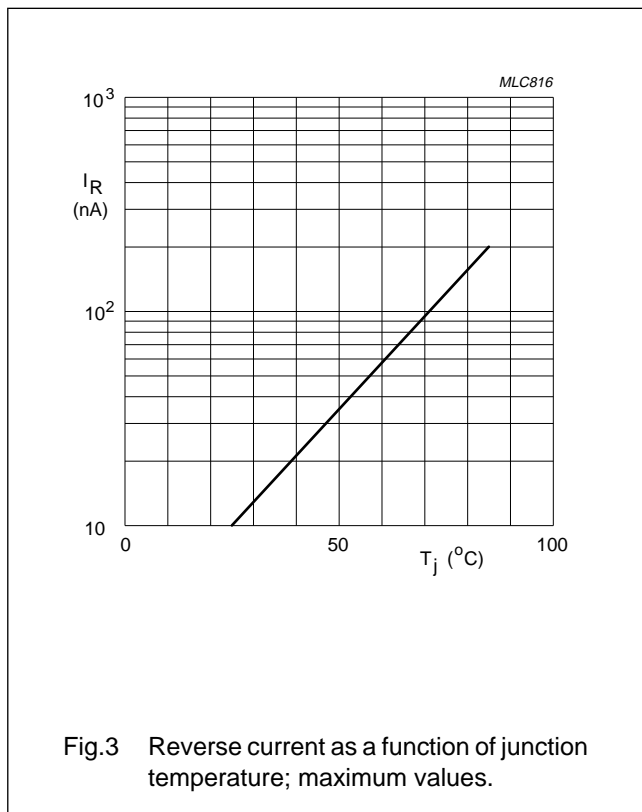
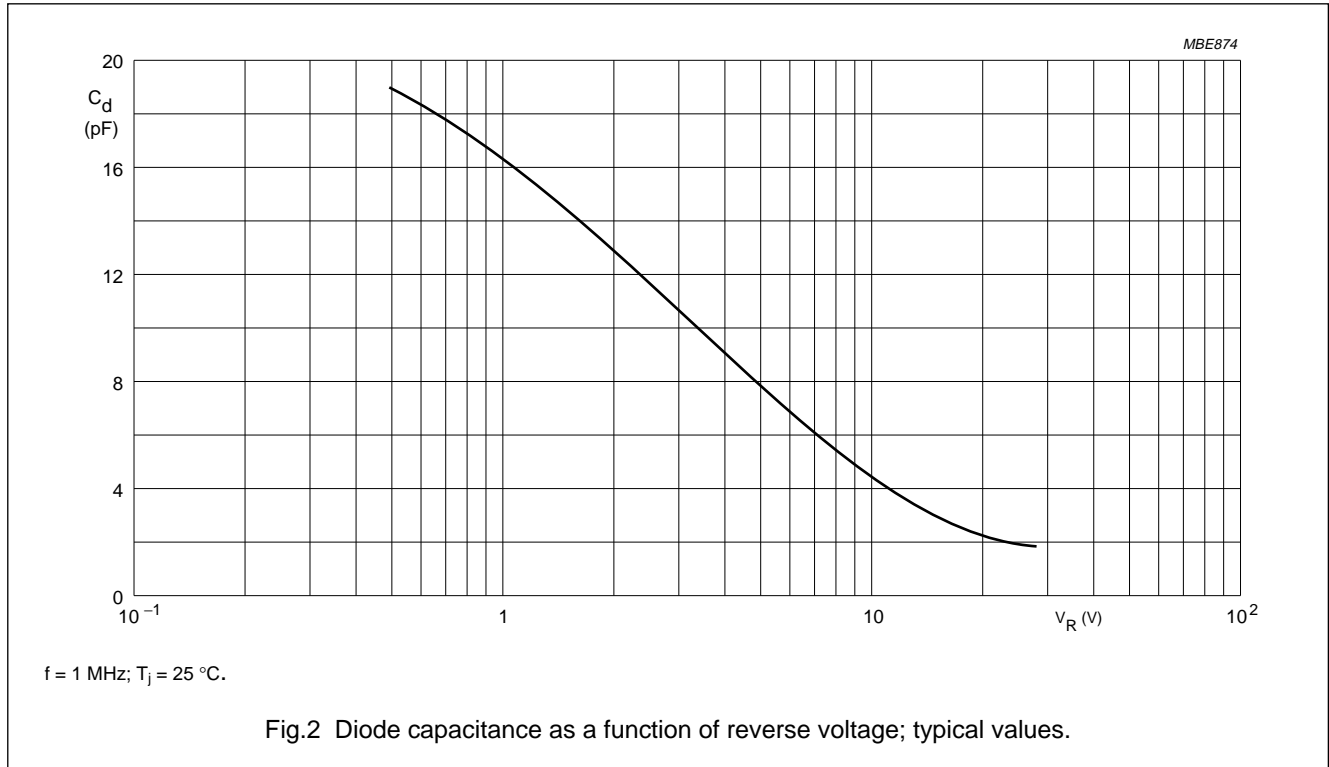

UHF variable capacitance diode

BB134

PACKAGE OUTLINE

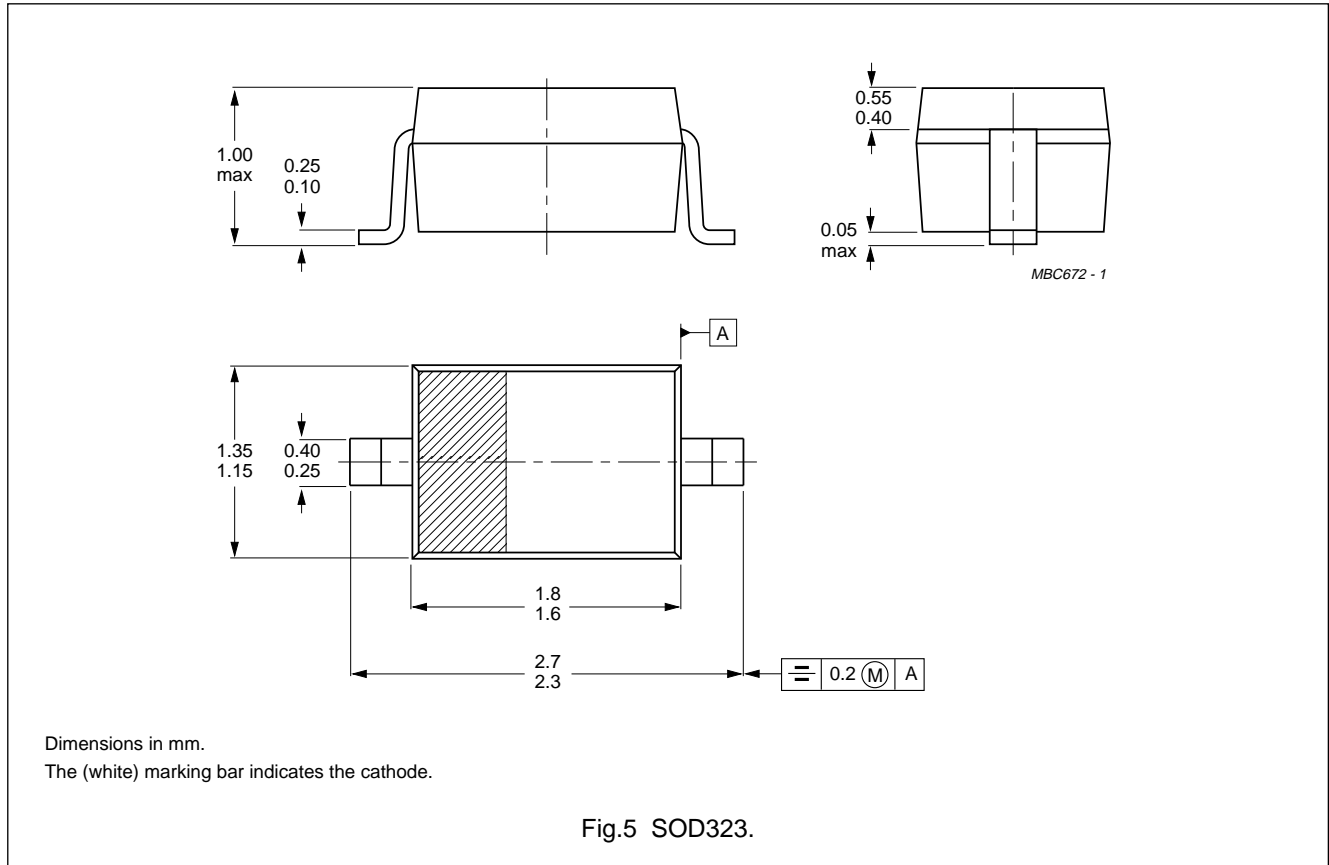

DEFINITIONS

Data sheet status	
Objective specification	This data sheet contains target or goal specifications for product development.
Preliminary specification	This data sheet contains preliminary data; supplementary data may be published later.
Product specification	This data sheet contains final product specifications.
Limiting values	
Limiting values given are in accordance with the Absolute Maximum Rating System (IEC 134). Stress above one or more of the limiting values may cause permanent damage to the device. These are stress ratings only and operation of the device at these or at any other conditions above those given in the Characteristics sections of the specification is not implied. Exposure to limiting values for extended periods may affect device reliability.	
Application information	
Where application information is given, it is advisory and does not form part of the specification.	

LIFE SUPPORT APPLICATIONS

These products are not designed for use in life support appliances, devices, or systems where malfunction of these products can reasonably be expected to result in personal injury. Philips customers using or selling these products for use in such applications do so at their own risk and agree to fully indemnify Philips for any damages resulting from such improper use or sale.